

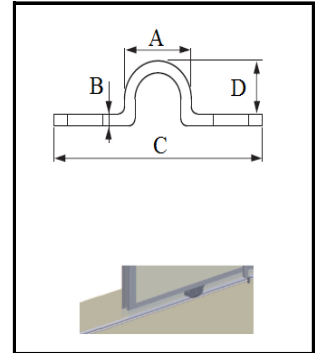

**ΟΔΗΓΟΣ
ΓΚΑΡΑΖΟΠΟΡΤΑΣ**

ΚΩΔ.	A	B	C	D	ΜΗΚΟΣ	
3091/20.3	20	3	55	13,5	3 ΜΕΤΡΑ	40

**ΟΔΗΓΟΣ
ΓΚΑΡΑΖΟΠΟΡΤΑΣ**

ΚΩΔ.	A	B	C	ΜΗΚΟΣ	
3094/20.3	20	3	60	3 ΜΕΤΡΑ	40

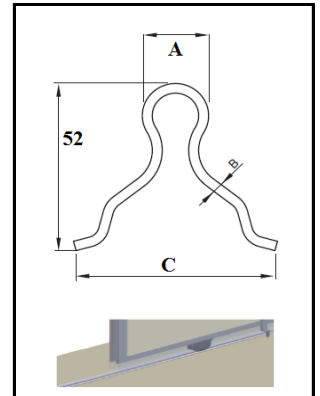
**ΠΙΡΟΣ ΣΥΝΔΕΣΗΣ
ΟΔΗΓΟΥ**

ΚΩΔ.	A	B	C	
3095	64	13	13,5	10

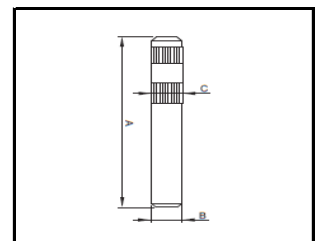
Εχουμε για εσάς δύο τύπους ροδών.

Την **Zincatura** που ήδη γνωρίζετε και την **ειδικής επεξεργασίας Cataforesi** που εγγυάται 10 φορές μεγαλύτερη αντοχή στη διάβρωση και την σκουριά !!!

Για την **Zinc** χρησιμοποιείτε τον αντίστοιχο κωδικό.

Για την **Cataforesi** χρησιμοποιείτε τον ίδιο κωδικό προσθέτοντας στο τέλος το γράμμα **C**

ZINCATURA
7μ. έως 11μ. Κλάση II



CATAFORESI
Ειδική Εποξειδική Πουέτρα - Ειδικό Ηλεκτροστατικό Βερνίκι - Φοσφάτιση για δεκαπλάσια προστασία

**ΡΟΔΑ ΓΚΑΡΑΖΟΠΟΡΤΑΣ
ΓΙΑ ΓΩΝΙΑ & ΤΑΦ
ΜΕ ΜΠΟΥΛΟΝΙ
& ΡΟΥΛΕΜΑΝ**

1 Cuscinetto
Mod. 2RS



ΚΩΔ.	Φ	A	B	C	D	E	
110/6/17	60	17	19	10	3,5	10x45	20
110/7/20	70	20	32	13	4	14x70	12
110/8/20	80	20	32	13	4	14x70	10
110/10/20	100	20	32	13	4	14x70	8
110/12/20	120	20	32	13	4	14x70	6
110/14/20	140	20	32	13	4	14x70	6

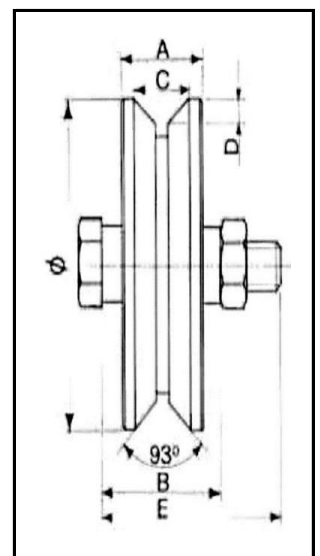



**ΡΟΔΑ ΓΚΑΡΑΖΟΠΟΡΤΑΣ
ΓΙΑ ΟΔΗΓΟ U
ΜΕ ΜΠΟΥΛΟΝΙ
& ΡΟΥΛΕΜΑΝ**

1 Cuscinetto
Mod. 2RS

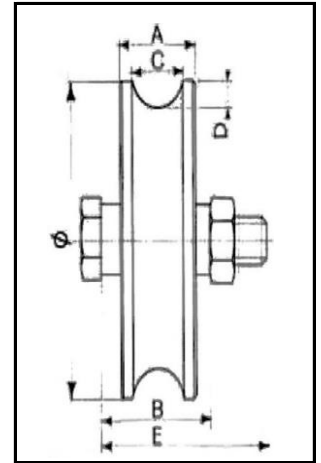

ΚΩΔ.	Φ	A	B	C	D	E	
111/8/25	80	25	32	20	10	14x70	8
111/10/25	100	25	32	20	10	14x70	6
111/12/25	120	25	32	20	10	14x70	6
111/14/25	140	25	32	20	10	14x70	6

**ΡΟΔΑ ΓΚΑΡΑΖΟΠΟΡΤΑΣ
ΧΩΝΕΥΤΗ ΜΕ ΒΑΣΗ
ΓΙΑ ΓΩΝΙΑ ΚΑΙ ΤΑΦ
ΜΕ ΡΟΥΛΕΜΑΝ**

1 Cuscinetto
Mod. 2RS

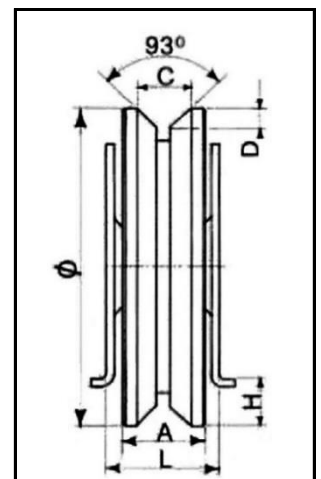

ΚΩΔ.	Φ	A	C	D	H	L	
130/6/17	60	17	10	3,5	8,5	25	24
130/8/20	80	20	13	4	12	33	20
130/10/20	100	20	13	4	22	33	12
130/12/20	120	20	13	4	18	33	6
130/14/20	140	20	13	4	28	33	6

**ΡΟΔΑ ΓΚΑΡΑΖΟΠΟΡΤΑΣ
ΧΩΝΕΥΤΗ ΜΕ ΒΑΣΗ
ΓΙΑ ΟΔΗΓΟ U
ΜΕ ΡΟΥΛΕΜΑΝ**

1 Cuscinetto
Mod. 2RS

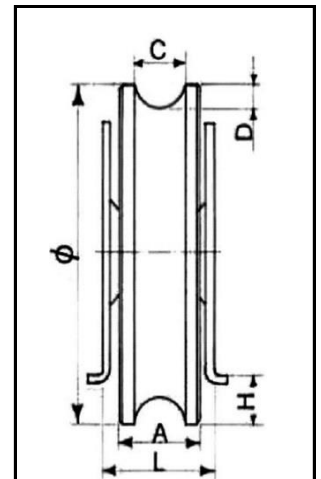

ΚΩΔ.	Φ	A	C	D	H	L	
131/8/25	80	25	20	10	12	33	20
131/10/25	100	25	20	10	22	33	12
131/12/25	120	25	20	10	18	33	8
131/14/25	140	25	20	10	28	33	6

**ΡΟΔΑ ΓΚΑΡΑΖΟΠΟΡΤΑΣ
ΧΩΝΕΥΤΗ ΜΕ ΒΑΣΗ
ΓΙΑ ΟΔΗΓΟ U
ΜΕ 2 ΡΟΥΛΕΜΑΝ**

2 Cuscinetti
Mod. 2RS

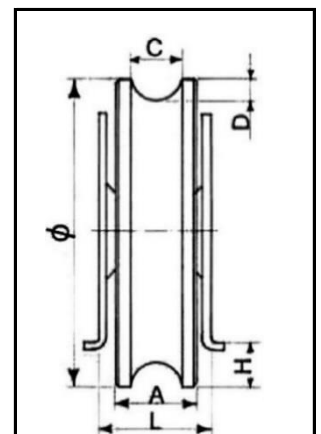

ΚΩΔ.	Φ	A	C	D	H	L	
131/10/32/2	100	32	20	10	22	44	8
131/12/32/3	120	32	20	10	18	44	6
131/14/32/4	140	32	20	10	28	44	4

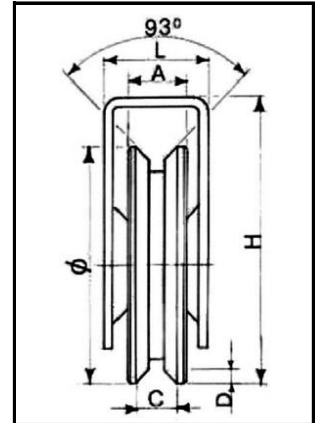

NOVA-FERR srl®

 La Garanzia del
PRODOTTO made in **ITALY**
**ΡΟΔΑ ΓΚΑΡΑΖΟΠΟΡΤΑΣ
 ΕΞΩΤΕΡΙΚΗ ΜΕ ΒΑΣΗ
 ΓΙΑ ΓΩΝΙΑ ΚΑΙ ΤΑΦ
 ΜΕ ΡΟΥΛΕΜΑΝ**

 1 Cuscinetto
 Mod. 2RS

ΚΩΔ.	Φ	A	C	D	H	L	
140/8/20	80	20	13	4	95	36	15
140/10/20	100	20	13	4	105	36	12

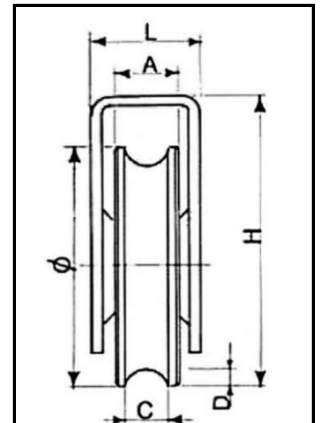
**ΡΟΔΑ ΓΚΑΡΑΖΟΠΟΡΤΑΣ
 ΕΞΩΤΕΡΙΚΗ ΜΕ ΒΑΣΗ
 ΓΙΑ ΟΔΗΓΟ U
 ΜΕ ΡΟΥΛΕΜΑΝ**

 1 Cuscinetto
 Mod. 2RS

ΚΩΔ.	Φ	A	C	D	H	L	
141/8/20	80	20	16	8	95	36	15
141/10/20	100	20	16	8	105	36	12

ΟΔΗΓΟΣ NYLON

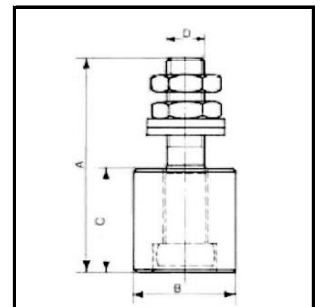

ΚΩΔ.	A	B	C	D	NYLON	
154/1.2	74	30	40	14	ΑΣΠΙΡΟ	30
154/2.2	84	40	40	14	ΑΣΠΙΡΟ	25
154/3.2	102	40	60	16	ΑΣΠΙΡΟ	30

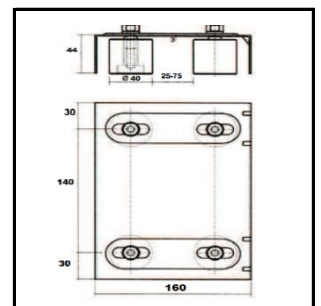

**ΒΑΣΗ ΟΔΗΓΟΥ
 ΜΕ 4 ΡΟΔΕΣ
 NYLON ΑΣΠΡΕΣ**

ΚΩΔ.	
153/2	4

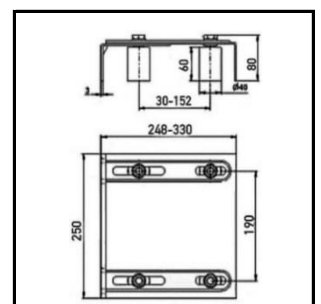

**ΒΑΣΗ ΟΔΗΓΟΥ
 ΜΕ 4 ΡΟΔΕΣ
 NYLON ΑΣΠΡΕΣ**

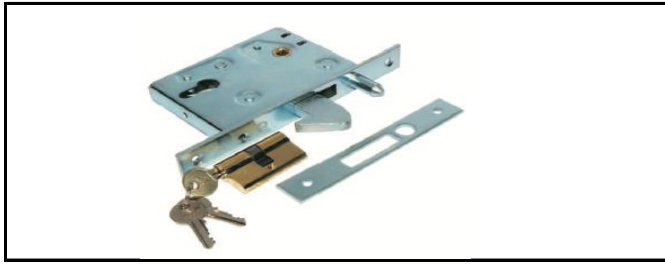
ΚΩΔ.	
153/4	4



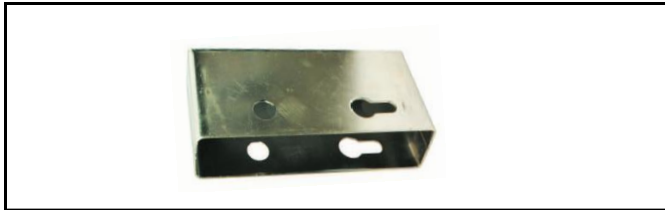
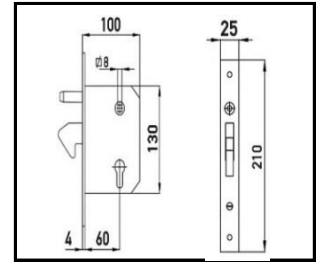

NOVA-FERR srl[®]
**La Garanzia del
PRODOTTO made in ITALY**

**ΚΛΕΙΔΑΡΙΑ ΓΑΤΖΟΥ
ΜΕ ΑΦΑΛΟ**

ΚΩΔ.	
156/1	1

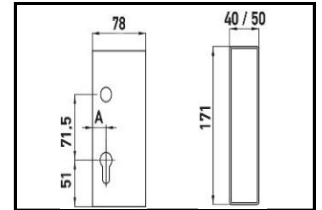
ΚΟΥΤΙ ΚΛΕΙΔΑΡΙΑΣ

ΚΩΔ.	
156/1.10	1

ΣΤΟΠΕΡ ΓΚΑΡΑΖΟΠΟΡΤΑΣ

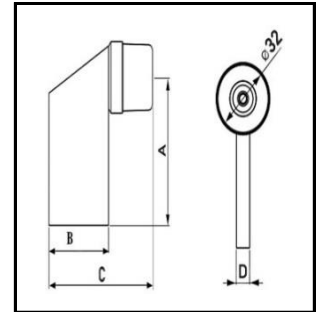

ΚΩΔ.	A	B	C	D	NYLON	
151/1	66	50	86	8	ΜΑΥΡΟ	25
151/2	87	70	108	10	ΜΑΥΡΟ	25

**ΜΥΛΟΣ ΜΕ ΓΡΑΣΑΔΟΡΟ
ΡΥΘΜΙΣΤΗ
& ΡΟΥΛΕΜΑΝ**

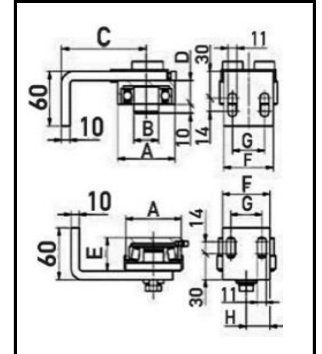

ΚΩΔ.	A	B	D	E	F	C / kg	
164	50	25	22	32	50	81-93 / 400 Kg	2
166	70	30	26	39	60	100-112/750 Kg	2

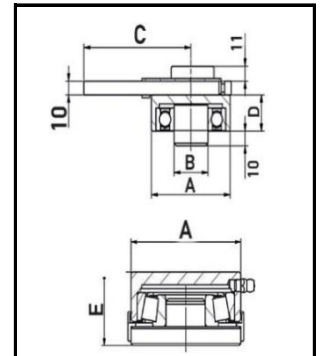
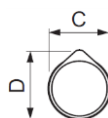

**ΜΥΛΟΣ ΜΕ ΓΡΑΣΑΔΟΡΟ
ΡΥΘΜΙΣΤΗ
& ΡΟΥΛΕΜΑΝ**

ΚΩΔ.	A	B	C	D	E	kg	
165	50	25	72-84	22	32	400 Kg	2
170	70	30	92-104	26	39	750 Kg	2

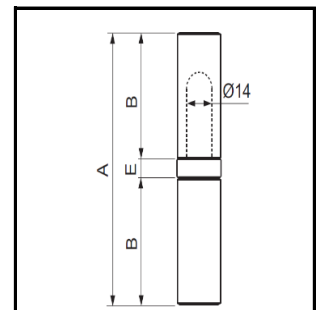

**ΜΕΝΤΕΣΣΕΣ (100άρης)
ΔΑΚΡΥ
ΜΕ ΡΟΥΛΕΜΑΝ**

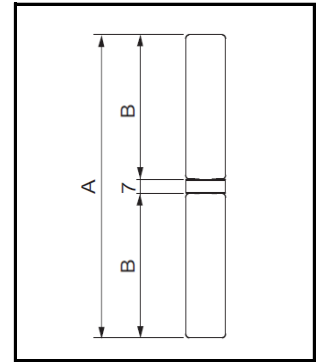
ΚΩΔ.	A	B	C	D	
176.2.4	101	47	22	25	20

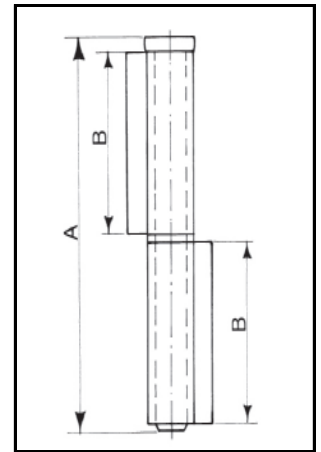
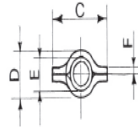

**ΜΕΝΤΕΣΕΣ (150άρης)
ΔΑΚΡΥ
ΜΕ ΡΟΥΛΕΜΑΝ**

ΚΩΔ.	A	B	C	D	ΠΙΡΟΣ	
197/20.1.4	147	70	20	25	INOX	20
197/20.2.4	147	70	20	25	ΑΤΣΑΛΙ	20

**ΜΕΝΤΕΣΕΣ
ΑΠΛΟΣ**

ΚΩΔ.	A	B	C	D	E	ΠΙΡΟΣ	
179/6	60	27	22	12	8	ΕΠΙΝΙΚΕ- ΛΩΜΕΝΟ ΑΤΣΑΛΙ	40
179/8	80	37	22	12	8		40
179/10	100	46	26	14,5	10		40
179/12	120	55	28	15	10		25
179/14	140	65	29	16	11		25

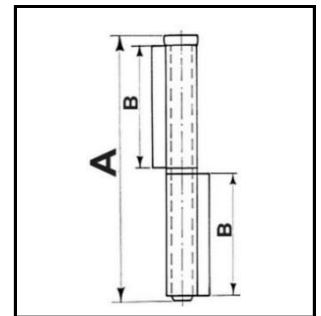
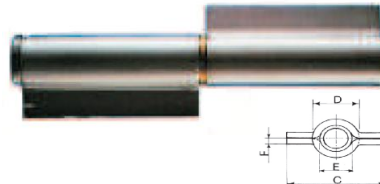
**ΜΕΝΤΕΣΕΣ ΒΑΡΕΩΣ ΤΥΠΟΥ
ΔΙΠΛΟΣ
ΜΕ ΡΟΥΛΕΜΑΝ**

ΚΩΔ.	A	B	C	D	E	F	
188/20.4	210	98	62	28	20	4	8

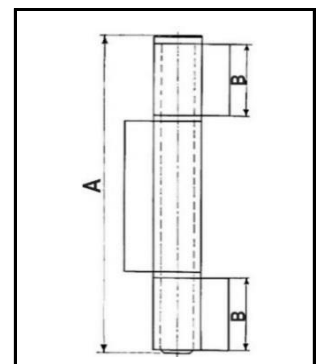
**ΜΕΝΤΕΣΕΣ
ΒΑΡΕΩΣ ΤΥΠΟΥ
ΤΡΙΠΛΟΣ
ΜΕ ΡΟΥΛΕΜΑΝ**

ΚΩΔ.	A	B	C	D	E	F	
189/20.4	210	47	62	28	20	4	8

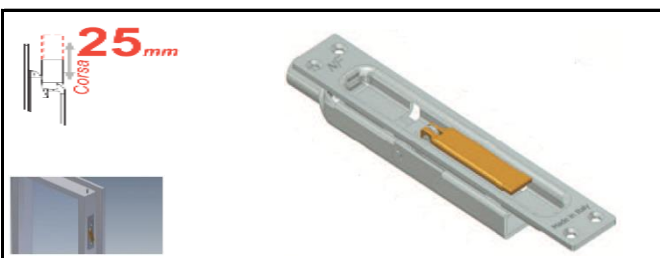
**ΧΩΝΕΥΤΟΣ ΣΥΡΤΗΣ
ΜΟΝΟΣ (ΠΑΝΩ)**
Με Ορειγάλκινο Μοχλό

ΚΩΔ.	
123.3.25	12

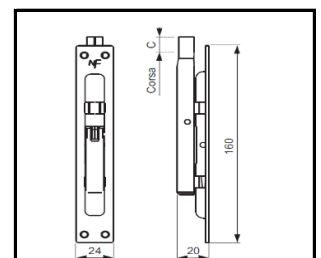

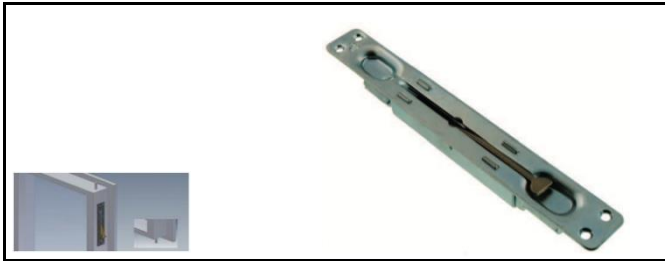
**ΧΩΝΕΥΤΟΣ ΣΥΡΤΗΣ
ΔΙΠΛΟΣ (ΠΑΝΩ/ΚΑΤΩ)**
Με Ορειχάλκινο Μοχλό
ΚΩΔ.

128

15

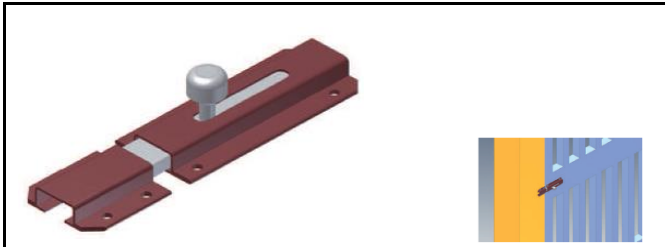
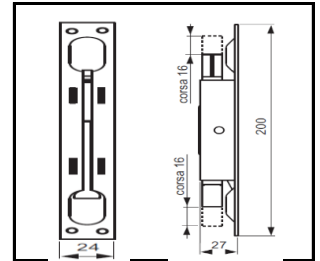
ΣΥΡΤΗΣ ΠΛΑΚΕ
ΚΩΔ.

259/50

20

259/70

20

259/90

20

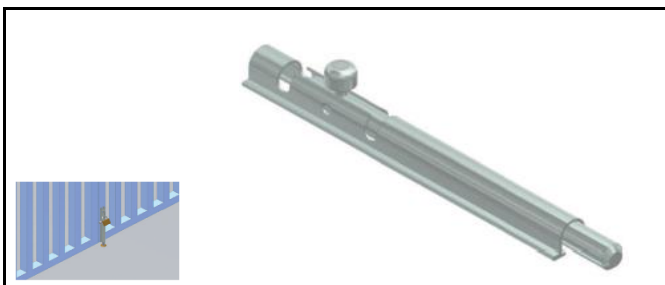
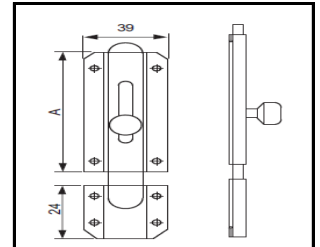
**ΣΥΡΤΗΣ ΛΟΥΚΕΤΟΥ
ΣΤΕΝΟΣ ΚΟΛΛΗΤΟΣ**
ΚΩΔ.

262/20

20

262/30

20

262/40

20

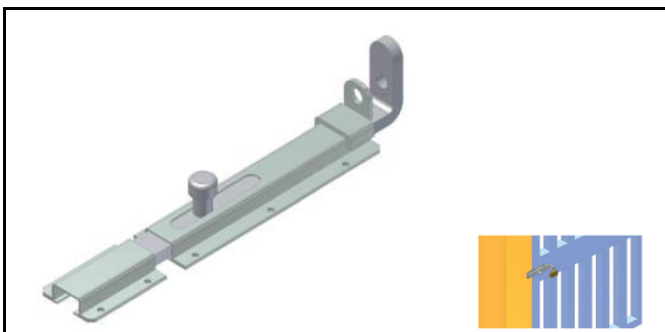
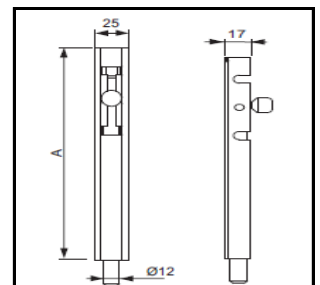
**ΣΥΡΤΗΣ ΛΟΥΚΕΤΟΥ
ΠΛΑΚΕ
ΒΑΡΕΩΣ ΤΥΠΟΥ**
ΚΩΔ.

264/20

8

264/30

6

264/40

6

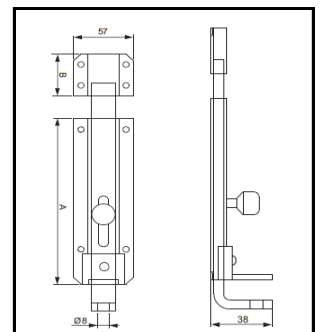
Γιατί να επιλέξετε την ειδική επεξεργασία CATAFORESI για τις ρόδες σας?
Γιατί σας εξασφαλίζει: Καλύτερη Λειτουργία - Μεγαλύτερη Αντοχή στη Διάβρωση
10 φορές μεγαλύτερη αντοχή στη σκουριά από το γαλβάνισμα !!!
Το TEST των 500 ωρών σε αλατονέφος το απέδειξε !!!

Πριν TEST 500 Ωρών σε Αλατονέφος	ZINCATURA 	CATAFORESI 	
	Μετά	ZINCATURA 	

INTERNATIONAL REFERENCE LAWS ARE:

- **ASTM B 117:** Salt Spray (Fog) Test
- **UNI EN ISO 9227:** Corrosion tests in artificial environments

Salt Spray Fog Tests:
The treatment guarantees an optimal resistance to salt spray fog of more than 500 hours.